

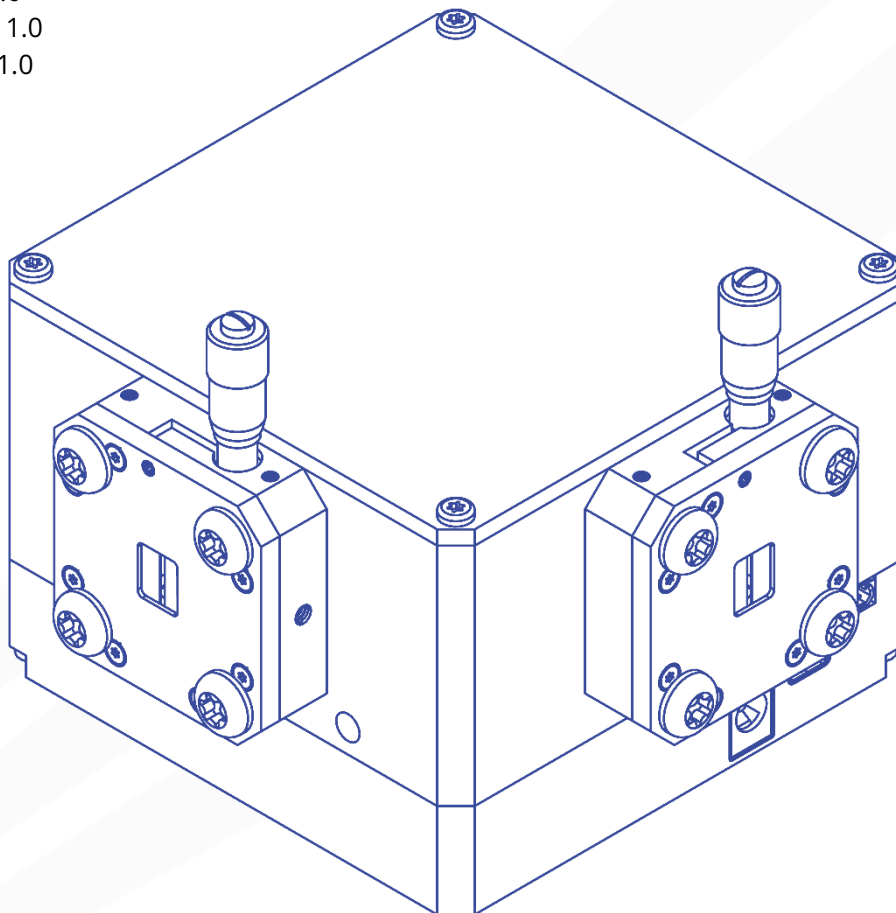

MONOCHROMATOR

USER MANUAL

Manual version: 1.0.0
Product code: G3001
Product Version: 1.0
Firmware Version: 1.0
Software version: 1.0



Contents

1. EU Declaration of Conformity	3
2. Safety	6
2.1 Use of Equipment.....	6
2.2 Hazard Icons	6
2.3 General Hazards.....	6
2.4 Power Cord Safety.....	6
2.5 Servicing	7
2.6 Health and Safety – Servicing.....	7
3. Requirements	8
4. Unpacking	9
4.1 Packing List	9
4.2 Damage Inspection	9
5. Specifications	10
6. Installation	10
7. Operation	11
7.1 Command Library	11
7.2 Monochromator Console	14
8. User Calibration	17
8.1 Using Serial Commands.....	17
8.2 Using Monochromator Console.....	18
9. Troubleshooting	22
10. Related Products	23

1. EU Declaration of Conformity

We

Company Name: Ossila BV

Postal Address: Biopartner 3 building, Galileiweg 8

Postcode: 2333 BD Leiden

Country: The Netherlands

Telephone number: +31 (0)71 3322992

Email Address: info@ossila.com

declare that the DoC is issued under our sole responsibility and belongs to the following product:

Product: Monochromator (G3001A1)

Serial number: G3001A1-xxxx

Object of declaration:

Monochromator (G3001A1)

The object of declaration described above is in conformity with the relevant Union harmonisation legislation:

EMC Directive 2014/30/EU

RoHS Directive 2011/65/EU

Signed:



Name: Dr James Kingsley

Place: Leiden

Date: 26/11/2025

[Декларация] за съответствие на ЕС

Производител: Ossila BV, Biopartner 3 building, Galileiweg 8, 2333 BD Leiden, NL.

Декларира с цялата си отговорност, че посоченото оборудване съответства на приложимото законодателство на ЕС за хармонизиране, посочено на предходната(-ите) страница(-и) на настоящия документ.

[Čeština] Prohlášení o shodě EU

Výrobce: Ossila BV, Biopartner 3 building, Galileiweg 8, 2333 BD Leiden, NL.

Prohlašujeme na vlastní odpovědnost, že uvedené zařízení je v souladu s příslušnými harmonizačními předpisy EU uvedenými na předchozích stranách tohoto dokumentu.

[Dansk] EU-overensstemme Iserklæring

Producent: Ossila BV, Biopartner 3 building, Galileiweg 8, 2333 BD Leiden, NL.

Erklærer herved, at vi alene er ansvarlige for, at det nævnte udstyr er i overensstemmelse med den relevante EU-harmoniseringslovgivning, der er anført på den/de foregående side(r) i dette dokument.

[Deutsch] EU-Konformitätserklärung

Hersteller: Ossila BV, Biopartner 3 building, Galileiweg 8, 2333 BD Leiden, NL.

Wir erklären in alleiniger Verantwortung, dass das aufgeführte Gerät konform mit der relevanten EU-Harmonisierungsgesetzgebung auf den vorangegangenen Seiten dieses Dokuments ist.

[Eesti keel] ELi vastavusavaldus

Tootja: Ossila BV, Biopartner 3 building, Galileiweg 8, 2333 BD Leiden, NL.

Kinnitame oma ainuvastutuse, et loetletud seadmed on kooskõlas antud dokumendi eelmisel lehelküljel / eelmistel lehekülgedel ära toodud asjaomaste ELi ühtlustamise õigusaktidega.

[Ελληνικά] Δήλωση πιστότητας ΕΕ

Κατασκευαστής: Ossila BV, Biopartner 3 building, Galileiweg 8, 2333 BD Leiden, NL.

Δηλώνουμε υπεύθυνα ότι ο αναφερόμενος εξοπλισμός συμμορφώνεται με τη σχετική νομοθεσία εναρμόνισης της ΕΕ που υπάρχει στις προηγούμενες σελίδες του παρόντος εγγράφου.

[Español] Declaración de conformidad UE

Fabricante: Ossila BV, Biopartner 3 building, Galileiweg 8, 2333 BD Leiden, NL.

Declaramos bajo nuestra única responsabilidad que el siguiente producto se ajusta a la pertinente legislación de armonización de la UE enumerada en las páginas anteriores de este documento.

[Français] Déclaration de conformité UE

Fabricant: Ossila BV, Biopartner 3 building, Galileiweg 8, 2333 BD Leiden, NL.

Déclarons sous notre seule responsabilité que le matériel mentionné est conforme à la législation en vigueur de l'UE présentée sur la/les page(s) précédente(s) de ce document.

[Hrvatski] E.U izjava o sukladnosti

Proizvođač: Ossila BV, Biopartner 3 building, Galileiweg 8, 2333 BD Leiden, NL.

Izjavljujemo na vlastitu odgovornost da je navedena oprema sukladna s mjerodavnim zakonodavstvom EU-a o usklađivanju koje je navedeno na prethodnoj(nim) stranici(ama) ovoga dokumenta.

[Italiano] Dichiarazione di conformità UE

Produttore: Ossila BV, Biopartner 3 building, Galileiweg 8, 2333 BD Leiden, NL.

Si dichiara sotto la propria personale responsabilità che l'apparecchiatura in elenco è conforme alla normativa di armonizzazione UE rilevante indicata nelle pagine precedenti del presente documento.

[Latviešu] ES atbils tības deklarācija

Ražotājs: Ossila BV, Biopartner 3 building, Galileiweg 8, 2333 BD Leiden, NL.

Ar pilnu atbildību paziņojam, ka uzskaitītais aprīkojums atbilst attiecīgajiem ES saskaņošanas tiesību aktiem, kas minēti iepriekšējās šī dokumenta lapās.

[Lietuvių k.] ES atitikties deklaracija

Gamintojas: Ossila BV, Biopartner 3 building, Galileiweg 8, 2333 BD Leiden, NL.

atsakingai pareiškia, kad išvardinta įranga atitinka aktualius ES harmonizavimo teisės aktus, nurodytus ankstesniuose šio dokumento

[Magyar] EU-s megfeleléségi nyilatkozat

Gyártó: Ossila BV, Biopartner 3 building, Galileiweg 8, 2333 BD Leiden, NL.
Kizárólagos felelősségünk mellett kijelentjük, hogy a felsorolt eszköz megfelel az ezen dokumentum előző oldalán/oldalain található EU-s összehangolt jogszabályok vonatkozó rendelkezéseinek.

[Nederlands] EU-Conformiteitsverklaring

Fabrikant: Ossila BV, Biopartner 3 building, Galileiweg 8, 2333 BD Leiden, NL.
Verklaart onder onze uitsluitende verantwoordelijkheid dat de vermelde apparatuur in overeenstemming is met de relevante harmonisatiewetgeving van de EU op de vorige pagina('s) van dit document.

[Norsk] EU-samsvarserklæring

Produsent: Ossila BV, Biopartner 3 building, Galileiweg 8, 2333 BD Leiden, NL.
Erklærer under vårt eneansvar at utstyret oppført er i overholdelse med relevant EU-harmoniseringslovverk som står på de(n) forrige siden(e) i dette dokumentet.

[Polski] Deklaracja zgodności Unii Europejskiej

Producent: Ossila BV, Biopartner 3 building, Galileiweg 8, 2333 BD Leiden, NL.
Oświadczamy na własną odpowiedzialność, że podane urządzenie jest zgodne ze stosownymi przepisami harmonizacyjnymi Unii Europejskiej, które przedstawiono na poprzednich stronach niniejszego dokumentu.

[Por tuguês] Declaração de Conformidade UE

Fabricante: Ossila BV, Biopartner 3 building, Galileiweg 8, 2333 BD Leiden, NL.
Declara sob sua exclusiva responsabilidade que o equipamento indicado está em conformidade com a legislação de harmonização relevante da UE mencionada na(s) página(s) anterior(es) deste documento.

[Română] Declarație de conformitate UE

Producător: Ossila BV, Biopartner 3 building, Galileiweg 8, 2333 BD Leiden, NL.
Declară pe proprie răspundere că echipamentul prezentat este în conformitate cu prevederile legislației UE de armonizare aplicabile prezentate la pagina/paginile anterioare a/ale acestui document.

[Slovensky] Vyhlásenie o zhode pre EÚ

Výrobca: Ossila BV, Biopartner 3 building, Galileiweg 8, 2333 BD Leiden, NL.
Na vlastnú zodpovednosť prehlasuje, že uvedené zariadenie je v súlade s príslušnými právnymi predpismi EÚ o harmonizácii uvedenými na predchádzajúcich stranách tohto dokumentu.

[Slovenščina] Izjava EU o skladnosti

Proizvajalec: Ossila BV, Biopartner 3 building, Galileiweg 8, 2333 BD Leiden, NL.
s polno odgovornostjo izjavlja, da je navedena oprema skladna z veljavno uskladitveno zakonodajo EU, navedeno na prejšnji strani/prejšnjih straneh tega dokumenta.

[Suomi] EU-vaatimusten mukaisuusvakuutus

Valmistaja: Ossila BV, Biopartner 3 building, Galileiweg 8, 2333 BD Leiden, NL.
Vakuutamme täten olevamme yksin vastuussa siitä, että tässä asiakirjassa luetellut laitteet ovat tämän asiakirjan sivuilla edellisillä sivuilla kuvattujen olennaisten yhdenmukaistamista koskevien EU-säädösten vaatimusten mukaisia.

[Svenska] EU-försäkran om överensstämmelse

Tillverkare: Ossila BV, Biopartner 3 building, Galileiweg 8, 2333 BD Leiden, NL.
Vi intygar härmed att den utrustning som förtecknas överensstämmer med relevanta förordningar gällande EU-harmonisering som finns på föregående sidor i detta dokument.

2. Safety

2.1 Use of Equipment

The Ossila Monochromator is designed to be used as instructed. It is intended for use under the following conditions:

- Indoors in a laboratory environment (Pollution Degree 2)
- Altitudes up to 2000m
- Temperatures of 5°C to 40°C; maximum relative humidity of 80% up to 31°C.

The unit is supplied with a 24 VDC power adapter, in accordance with European Commission regulations and British Standards. Use of any other electrical power cables, adaptors, or transformers is not recommended.

2.2 Hazard Icons

The following symbols can be found at points throughout the rest of the manual. Note and read each warning before attempting any associated operations associated with it:

Table 2.1. Hazard warning labels used in this manual.

Symbol	Associated Hazard
	Electrical shock

2.3 General Hazards

Before installing or operating the Ossila Monochromator there are several health and safety precautions which must be followed and executed to ensure safe installation and operation.

2.4 Power Cord Safety



Emergency power disconnect options: use the power cord as a disconnecting method and remove from wall. To facilitate disconnect, make sure the power outlet for this cord is readily accessible to the operator.

2.5 Servicing

If servicing is required, please return the unit to Ossila Ltd. The warranty will be invalidated if:

- Modification or service has been carried out by anyone other than an Ossila engineer.
- The Unit has been subjected to chemical damage through improper use.
- The Unit has been operated outside the usage parameters stated in the user documentation associated with the Unit.
- The Unit has been rendered inoperable through accident, misuse, contamination, improper maintenance, modification, or other external causes.

2.6 Health and Safety – Servicing



Servicing should only be performed by an Ossila engineer. Any modification or alteration may damage the equipment, cause injury, or death. It will also void your equipment's warranty.

3. Requirements

Table 3.1 details the requirements for the Ossila Monochromator, and the minimum computer specifications for the software.

Table 3.1. Ossila Monochromator requirements.

Power	24 VDC (supplied with the system)
Operating Systems	Windows 11 (64-bit)
CPU	Dual Core 2 GHz
RAM	4 GB
Available Hard Drive Space	187 MB
Monitor Resolution	1440 x 960
Connectivity	USB 2.0

4. Unpacking

4.1 Packing List

The standard items included with the Ossila Monochromator are:

- The Ossila Monochromator.
- 24 VDC power adaptor.
- USB-C cable.
- USB memory stick loaded with software installer, user manual, and calibration certificate.

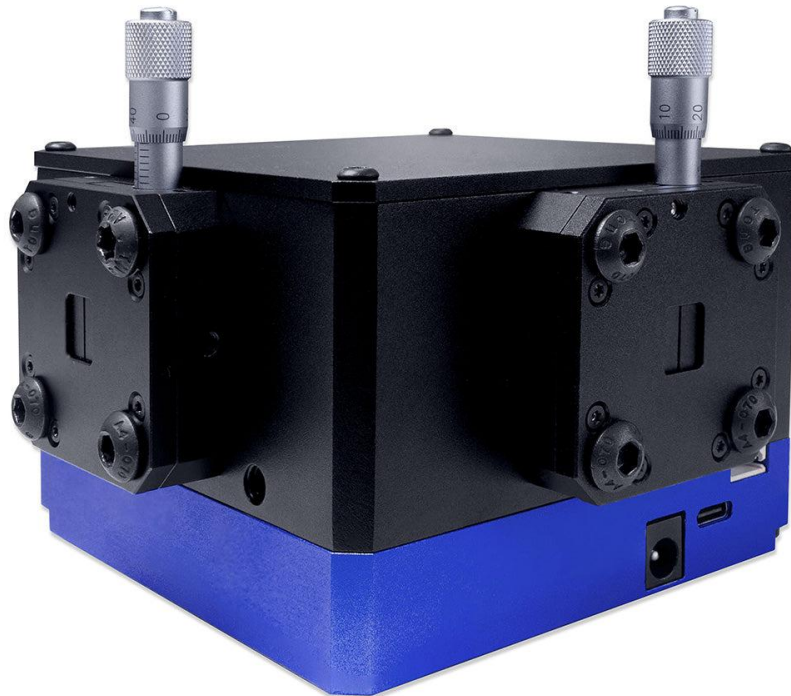

Figure 4.1. Ossila Monochromator.

4.2 Damage Inspection

Examine the components for evidence of shipping damage. If damage has occurred, please contact Ossila directly for further action. The shipping packaging will come with a shock indicator to show if there has been any mishandling of the package during transportation.

5. Specifications

The Ossila Monochromator specifications are shown in **Table 5.1**.

Table 5.1. Ossila Monochromator specifications.

Spectral Range	260 – 1100 nm (calibrated between 380 and 1000 nm)
Wavelength accuracy	<1 nm (in calibrated range)
Wavelength repeatability	<0.1 nm
Spectral resolution	Slit width dependant
Configuration	Crossed Czerny-Turner
f Number	f/4
Focal Length	100 mm
Ports	2
Slit Type	Manual – micrometer driven with 10 µm resolution
Slit Size	50 µm – 6 mm (W) x 10 mm (H)
Dimensions	113.5 mm (L) x 113.5 mm (W) x 100 mm (H)
Weight	1.1 kg

6. Installation

1. Connect the 24 VDC power adaptor to the power socket on the unit.
2. Connect the unit to your PC using a USB-C cable.

7. Operation

The Ossila Monochromator can be controlled either programmatically using serial commands, or through the Ossila Monochromator Console software.

7.1 Command Library

The primary interface of the Ossila Monochromator is the serial command library. When connected to a PC, the device will appear as a COM port, to which the serial commands can be sent. This section describes the command protocol and lists the available commands.

7.1.1 Command Format

Commands should be sent to the monochromator in ASCII format, and responses from the monochromator will also be in ASCII format.

All commands sent to the monochromator have a start and end delimiter, `<` and `>` respectively. Only commands enclosed by these delimiters will be acknowledged by the device. If any invalid commands are sent between delimiters, the system will return `<Invalid Command>`.

Commands are either set commands with the format `<command value>` or query commands with the format `<command?>`.

Set commands take between 0 and 2 values and each value must be separated by a space. If a command is successfully implemented, it will be echoed back.

Query commands allow the user to find current system settings without modifying them. If a query command is successfully interpreted, the system will return `<command value>`.

Set commands that have a corresponding query command list both commands together. In these cases, the set command value and query command return value have the same format.

Values will be one of the following types depending on the command:

- `float` – Floating-point number
 - l. These can be sent in scientific notation (for example, `123e4` or `123E4`).
- `int` – Integer
 - l. If a floating-point number is sent instead, it will be rounded down to an integer.
- `bool` – Boolean (0 or 1)
 - l. Non-zero integers or floating-point numbers will be interpreted as 1.
- `str` – String
 - l. Only used as returns in some query commands.

7.1.2 Movement Commands

Command	Values	Function
<wavelength X> <wavelength?>	X – float – output wavelength in nm	<p>Moves the grating to so the output wavelength of the monochromator is X nm. Setting X to 0 will give zeroth order output.</p> <p>This command homes the grating before moving to the set wavelength for improved accuracy.</p> <p>Query returns <Invalid Command> if a wavelength has not been set since power on.</p>
<wavelengthd X>	X – float – output wavelength in nm	<p>Moves the grating to so the output wavelength of the monochromator is X nm. Setting X to 0 will give zeroth order output.</p> <p>This command does not home the grating and provides a lower accuracy than <wavelength>. Queried using <wavelength?>.</p>
<home>	None	<p>Return the grating to the home position at a fixed speed, zeroing the position once home has been reached. Some commands require the stage to be homed before they can be used.</p> <p>Returns <home> when homing is complete.</p>
<move X Y>	X – int – distance to move in steps Y – int – speed in steps/s	<p>Move the grating by X steps with a speed of Y steps/s. X can be positive or negative.</p> <p>The recommended speed is 500 steps/s.</p>
<goto X>	X – int – position to move to in steps	<p>Move the grating to the position X at the grating's maximum speed. Will not execute if the grating has not been homed, instead returning <pos undef>.</p>
<stop>	None	<p>Decelerates the grating to a stop. Locks the grating at the stopped position.</p>

7.1.3 Calibration Commands

Command	Values/Returns	Function
<usercal <i>X</i> > <usercal?>	<i>X</i> – bool	0 sets the monochromator to use factory calibration, 1 sets the monochromator to use the user defined calibration.
<cubic <i>X</i> > <cubic?>	<i>X</i> – float	Sets the cubic coefficient of the calibration equation.
<quadratic <i>X</i> > <quadratic?>	<i>X</i> – float	Sets the quadratic coefficient of the calibration equation.
<linear <i>X</i> > <linear?>	<i>X</i> – float	Sets the linear coefficient of the calibration equation.
<constant <i>X</i> > <constant?>	<i>X</i> – float	Sets the constant of the calibration equation.
<zeroordersteps <i>X</i> > <zeroordersteps?>	<i>X</i> – int	Sets the grating position for zeroth order output.

7.1.4 Query Commands

Command	Returns	Function
<pos?>	<pos <i>int</i> >	Returns the current position of the grating in steps relative to the home position.
<device?>	<device <i>str</i> >	Returns the product code of the monochromator.
<serial?>	<serial <i>int</i> >	Returns the serial number of the monochromator.
<firmware?>	<firmware <i>int.int.int</i> >	Returns the firmware version of the monochromator in the format <i>major.minor.patch</i> .

7.2 Monochromator Console

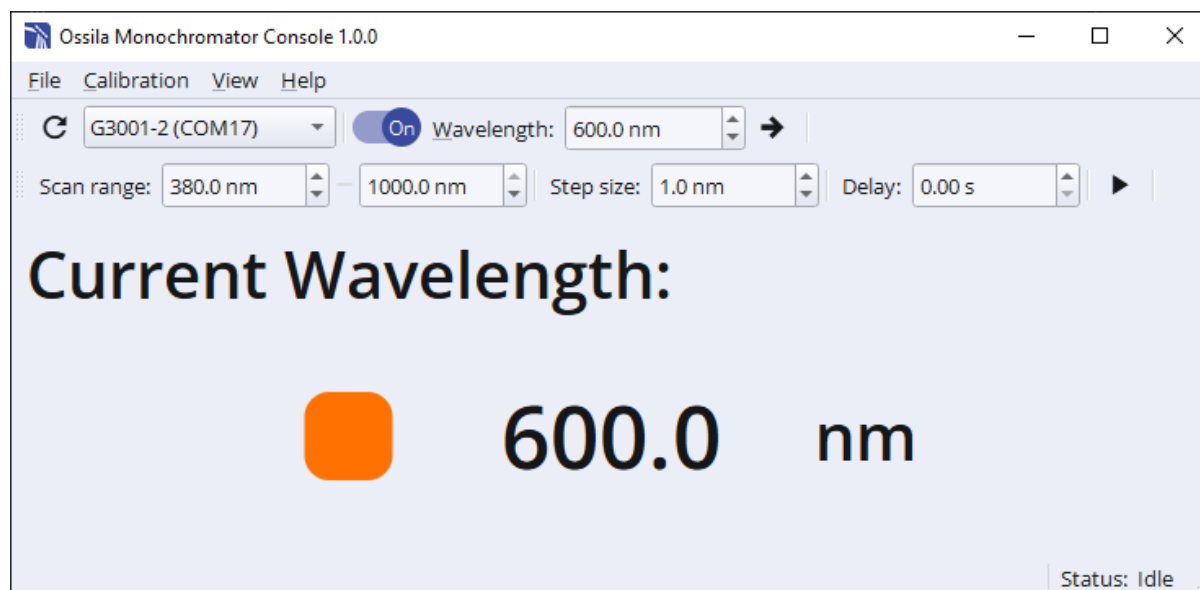

Figure 7.1. Ossila Monochromator Console.

Ossila provides free software to allow for simple use of the monochromator. A Windows installer is provided on the USB drive supplied with the system and can be downloaded from our website at www.ossila.com/pages/software-drivers.

To install the software simply run the installer and follow the on-screen instructions.

7.2.1 Control Tool Bar

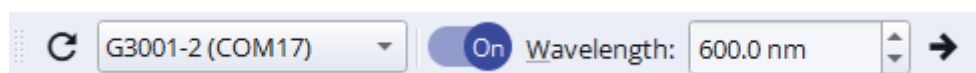
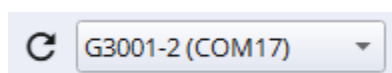

Figure 7.2. Monochromator Console control tool bar.

The control tool bar has the following sections:

(I) Connection



The drop-down box lists the serial numbers and addresses of any connected Ossila Monochromators.

Selecting a monochromator will connect to it, read the current output wavelength, and update the console accordingly.

To search for connected Ossila Monochromators, click the  button.

(II) Output Switch

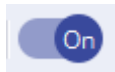

Toggles the output of the monochromator on and off. When off, the grating is in the home position.

(III) Wavelength Selection

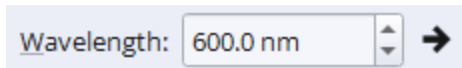

Set the output wavelength of the monochromator in nm.

The output will be changed when the → button is clicked or the **Enter** key is pressed.

7.2.2 Scan Tool Bar

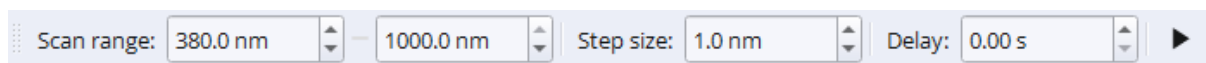

Figure 7.3. Monochromator Console scan tool bar.

Scans across wavelength ranges can be performed using the scan tool bar.

Scan Range	Sets the start and end output wavelength of a scan in nm. A scan can be performed in either direction (low to high or high to low).
Step Size	Sets how much the output wavelength will be changed by for each step in a scan in nm.
Delay	Sets how long, in seconds, to stay at each output wavelength step before moving onto the next.

To start a scan, click the ► button. To stop a scan, click the button again (while a scan is running the symbol changes to ■).

7.2.3 Menu Bar

(I) File Menu

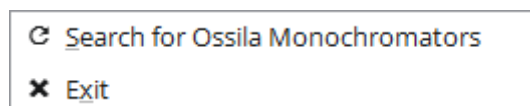

Figure 7.4. File menu.

Search for Ossila Monochromators	Search the USB ports and network for Ossila Monochromators. Discovered units will be displayed in the drop-down box in tool bar.
Exit	Close the software.

(II) Calibration Menu

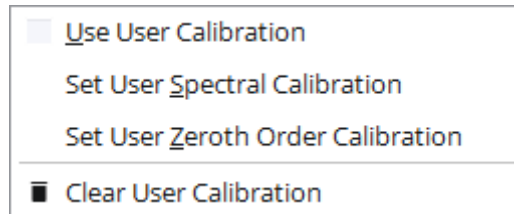

Figure 7.5. Calibration menu.

Use User Calibration	Toggles whether the monochromator uses the factory calibration or the user defined calibration.
Set User Spectral Calibration	Open the user spectral dialog. See Section 8 for more details.
Set User Zeroth Order Calibration	Open the user zeroth order calibration dialog. See Section 8 for more details.
Clear User Calibration	Reset the user calibration to the factory calibration.

(III) View Menu

Toggle Theme	Switch the software between light and dark themes.
---------------------	--

(IV) Help Menu

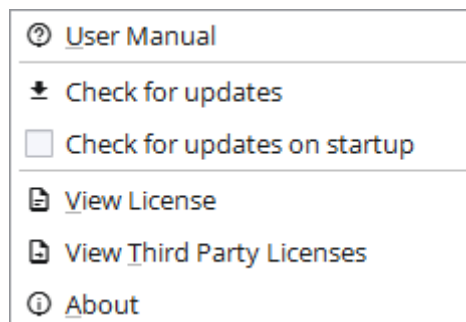

Figure 7.6. Help menu.

User Manual	Open the user manual in your default web browser.
Check for updates	Check whether a newer version of the software is available to download and install. If an update is available a message will be displayed in the status bar with the latest version number. Clicking the message will take you to Ossila's website where you can download the new version.
Check for Software Updates on Startup	When checked the software will automatically check for software updates each time it starts.
View License	Display software license information.
View Third Party License	Display the license information of third-party software that has been used in the software.
About	Display information about the software.

8. User Calibration

The monochromator allows for the user to calibrate the output wavelengths themselves. This can be done using serial commands or the Monochromator Console software. Both methods are described in this section.

In either case, to calibrate the monochromator you will need one or more light sources that span your required wavelength range (between 300 nm and 1000 nm) and a spectrometer.

8.1 Using Serial Commands

8.1.1 Spectral Calibration

To perform spectral calibration of the monochromator:

1. Align a light source with the entrance slit of the monochromator, and a spectrometer with the exit slit.
2. Home the monochromator grating using `<home>`.
3. Move the grating to output one wavelength of the light source's output, this can be done through either:
 - I. `<wavelength X>`, selecting a wavelength that is close to the required position.
 - II. `<move X Y>` or `<goto X>`, selecting a grating position which outputs light.
4. Measure the output spectrum with a spectrometer and record the peak wavelength in nanometres.
5. Query the grating position using `<pos?>` and record with the peak wavelength.
6. Repeat steps 2 to 5 until you have a good number of data points.
 - I. Be sure to measure at both ends of the desired wavelength range, otherwise you may get unexpected results.
 - II. The more data points measured, the better the calibration will be.

7. Fit a third order polynomial to the data, using the peak wavelengths as the x data and grating positions as the y data.
8. Set the calibration using the coefficients of the polynomial fit with <cubic X>, <quadratic X>, <linear X>, <constant X>.

8.1.2 Zeroth Order Calibration

To set the position of the zeroth order output:

1. Align a light source with the entrance slit of the monochromator, and a spectrometer with the exit slit.
2. Move the grating to the existing zeroth order position using <wavelength 0>.
3. Move the grating forwards or backwards using <move X 500> or <move -X 500>.
 - I. Moving by a single step is recommended.
4. Repeat until your spectrometer reads the strongest output of the light source's whole spectrum.
5. Read the position of the grating at the maximum using <pos?>.
6. Set the zeroth order position using <zeroordersteps X>.

8.2 Using Monochromator Console

8.2.1 Spectral Calibration

Spectral calibration with the Monochromator Console is performed in the Spectral Calibration window. To open the window, select in **Calibration** → **Set Spectral Calibration** the menu bar. The window in **Figure 8.1** will open.

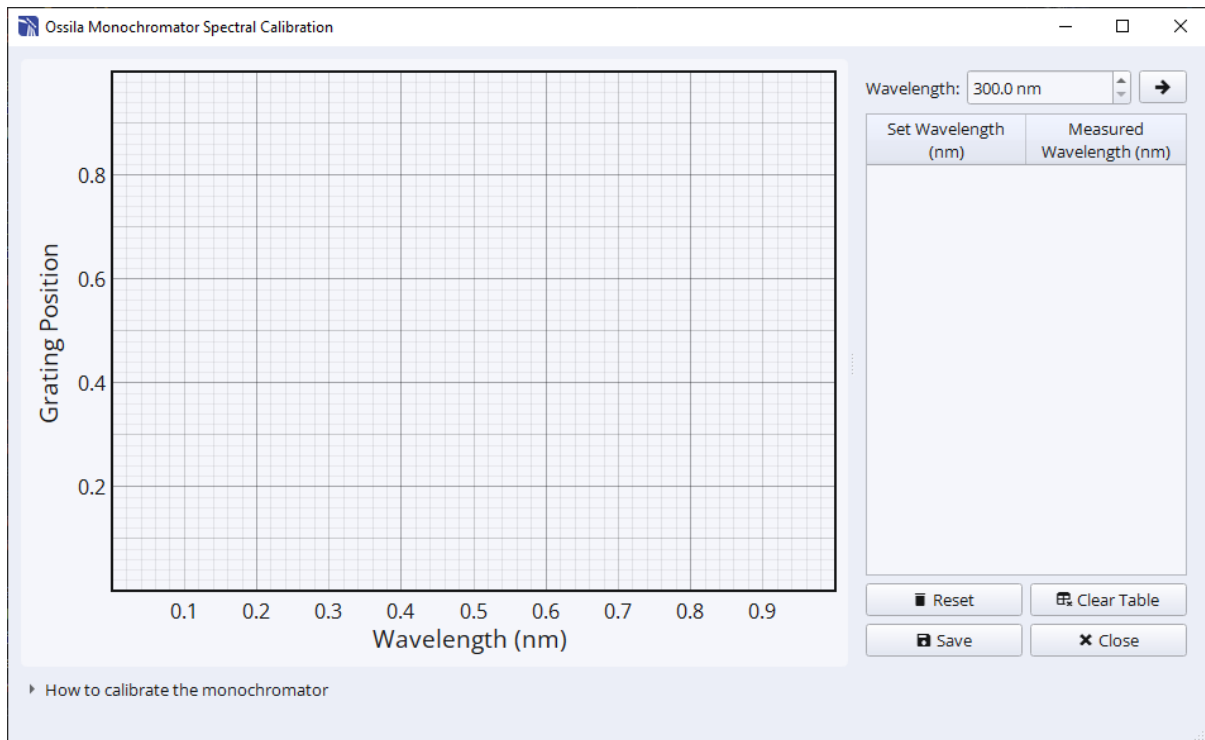

Figure 8.1. Spectral calibration window.

The Spectral Calibration window contains controls for calibrating the spectral output of the monochromator.

Wavelength:

Set the output wavelength of the monochromator in nm.

The output will be changed when the ➔ button is clicked or the **Enter** key is pressed. After the grating has moved, the set wavelength will be added to the table below.

	Set Wavelength (nm)	Measured Wavelength (nm)
1	300.00	302.00
2	400.00	401.00
3	500.00	0.00

Contains the set wavelengths that have been moved to and the measured wavelengths that have been entered.

Measured wavelength cells can be edited by clicking on the cell and typing in the new measured value. Double clicking the cell will display up and down arrows for increasing and decreasing the value.

Rows of data can be deleted by selecting the rows to delete and pressing the **Delete** key, or right-clicking and selecting **Delete Row(s)**.

When a measured wavelength is updated, the data in the table is displayed in the plot on the left. If there is more than one data point, a polynomial fit is applied to the data and displayed in the plot.

Below the table are the calibration controls, detailed below.



Figure 8.2. Spectral calibration controls.

Reset	Reset the user spectral calibration to factory values.
Clear Table	Clear all data from the table and restart the calibration procedure.
Save	Save the current spectral calibration values to the monochromator.
Close	Close the spectral calibration window.

Calibration Procedure

1. Align a light source with the entrance slit of the monochromator, and a spectrometer with the exit slit.
2. Set the output wavelength of monochromator to any value.
3. Measure the output spectrum with a spectrometer.
4. Enter the peak wavelength into the cell corresponding to the set wavelength in **Measured Wavelength** column of the data table.
5. Repeat steps 1 to 4 until you have a good number of data points.
 - I. Be sure to measure at both ends of the desired wavelength range, otherwise you may get unexpected results.
 - II. The more data points measured, the better the calibration will be.
6. Click the save button to save the calculated calibration coefficients to the monochromator.

8.2.2 Zeroth Order Calibration

Zeroth order calibration with the Monochromator Console is performed in the Zeroth Order Calibration window. To open the window, select in **Calibration** → **Set Zeroth Order Calibration** the menu bar. The window in Figure 8.3 will open.

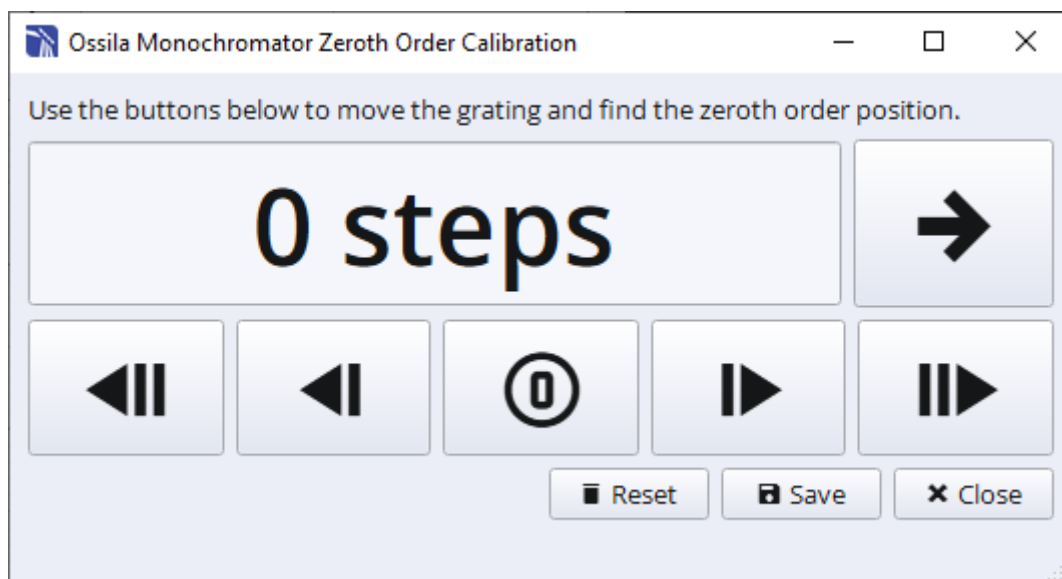









Figure 8.3. Zeroth order calibration window.

The Zeroth Order Calibration window displays the current position of the grating in steps and contains the following controls for setting the zeroth order position of the monochromator:

	The position display can be directly edited by clicking it and typing. Clicking this button moves the grating to the entered position.
	Move the grating 10 steps towards the home position.
	Move the grating 1 step towards the home position.
	Move the grating to the currently set zeroth order position.
	Move the grating 1 step away from the home position.
	Move the grating 10 steps away from the home position.
Reset	Reset the user zeroth order calibration to factory values.
Save	Save the current grating position to the monochromator.
Close	Close the calibration window.

Calibration Procedure

1. Align a light source with the entrance slit of the monochromator, and a spectrometer with the exit slit.
2. Move the grating to the existing zeroth order position using the  button.
3. Move the grating forwards or backwards using the movement buttons.
4. Repeat until your spectrometer reads the strongest output of the light source's whole spectrum.
5. Click the **Save** button to save the current position as the zeroth order position.

9. Troubleshooting

Most of the issues that may arise will be detailed here. However, if you encounter any issues that are not detailed here, then contact us by email at info@ossila.com. We will respond as soon as possible.

Problem	Possible Cause	Action
No power.	The power supply may not be connected properly.	Ensure the system is firmly plugged into the power supply, and that the plug is connected to both the adaptor and a working power socket.
	The power supply adaptor has a fault.	Contact Ossila for a replacement power supply adaptor.
Cannot connect to the system via USB.	The USB cable may not be connected properly.	Ensure the USB cable is firmly plugged in at both ends.
	The USB cable may not be connected to a working USB port.	Try connecting the unit to a different USB port on the computer.
	The USB cable is defective.	Try using a different USB-C cable and contact Ossila if necessary.
No light output.	The input and/or output slit is closed.	Open the closed slit.

10. Related Products



USB Spectrometer

Fully programmable, compact UV-Vis-NIR optical spectrometer.

Product codes: G2001A1



Broadband White Light Source

USB powered LED with a broad 360 nm – 900 nm output.

Product code: G2008B1

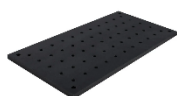

Optical Breadboard Plate

Solid anodized metric aluminium optical breadboard plate.

Product codes: G2007A1



Optical Filter

Longpass and shortpass filters in a range of wavelengths.

Product code: G2012



Silicon Photomultiplier

High sensitivity UV-VIS-NIR light detection with on-board signal processing.

Product code: G3002A1



LED Light Source

Reliable and consistent 380 – 1000 nm light for your spectroscopy experiments.

Product codes: G3003A1