

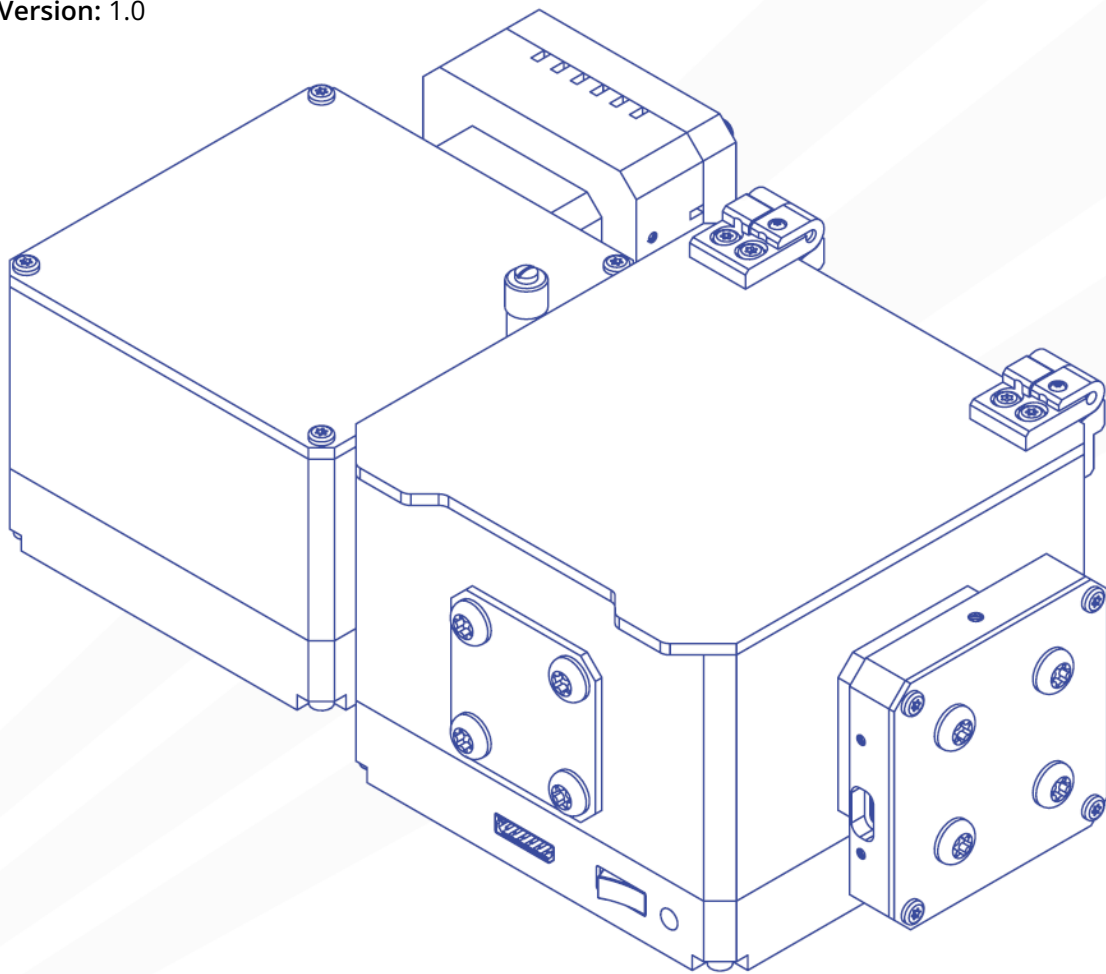

SPECTROPHOTOMETER

USER MANUAL

Manual version: 1.0.0
Product code: G3000B1
Product Version: 1.0



Contents

1. EU Declaration of Conformity	3
2. Safety	6
2.1 Use of Equipment.....	6
2.2 Hazard Icons	6
2.3 Power Cord Safety.....	6
2.4 Optical Hazards	7
2.5 Servicing	7
2.6 Health and Safety – Servicing.....	7
3. Requirements	8
4. Unpacking	9
4.1 Packing List	9
4.2 Damage Inspection	9
5. Specifications	10
6. Installation	10
7. Spectrophotometer Parts	11
8. Operation	13
8.1 Command Library	13
8.2 Spectrophotometry.....	16
9. Taking a Measurement	17
9.1 Absorbance/Transmission.....	17
9.2 Second Order Effects	17
10. Troubleshooting	18
11. Related Products	19

1. EU Declaration of Conformity

We

Company Name: Ossila BV

Postal Address: Biopartner 3 building, Galileiweg 8

Postcode: 2333 BD Leiden

Country: The Netherlands

Telephone number: +31 (0)71 3322992

Email Address: info@ossila.com

declare that the DoC is issued under our sole responsibility and belongs to the following product:

Product: Spectrofluorometer (G3000A1), Spectrophotometer (G3005A1)

Serial number: G3000A1-x, G3005A1-x

Object of declaration:

Spectrofluorometer (G3000A1), Spectrophotometer (G3005A1)

The object of declaration described above is in conformity with the relevant Union harmonisation legislation:

EMC Directive 2014/30/EU

RoHS Directive 2011/65/EU

Signed:



Name: Dr James Kingsley

Place: Leiden

Date: 04/03/2026

Декларация за съответствие на ЕС

Производител: Ossila BV, Biopartner 3 building, Galileiweg 8, 2333 BD Leiden, NL.

Декларира с цялата си отговорност, че посоченото оборудване съответства на приложимото законодателство на ЕС за хармонизиране, посочено на предходната(ите) страница(и) на настоящия документ.

[Čeština] Prohlášení o shodě EU

Výrobce: Ossila BV, Biopartner 3 building, Galileiweg 8, 2333 BD Leiden, NL.

Prohlašujeme na vlastní odpovědnost, že uvedené zařízení je v souladu s příslušnými harmonizačními předpisy EU uvedenými na předchozích stranách tohoto dokumentu.

[Dansk] EU-overensstemme Iserklæring

Producent: Ossila BV, Biopartner 3 building, Galileiweg 8, 2333 BD Leiden, NL.

Erklærer herved, at vi alene er ansvarlige for, at det nævnte udstyr er i overensstemmelse med den relevante EU-harmoniseringslovgivning, der er anført på den/de foregående side(r) i dette dokument.

[Deutsch] EU-Konformitätserklärung

Hersteller: Ossila BV, Biopartner 3 building, Galileiweg 8, 2333 BD Leiden, NL.

Wir erklären in alleiniger Verantwortung, dass das aufgeführte Gerät konform mit der relevanten EU-Harmonisierungsgesetzgebung auf den vorangegangenen Seiten dieses Dokuments ist.

[Eesti keel] ELi vastavusavaldus

Tootja: Ossila BV, Biopartner 3 building, Galileiweg 8, 2333 BD Leiden, NL.

Kinnitame oma ainuvastutust, et loetletud seadmed on kooskõlas antud dokumendi eelmisel lehelküljel / eelmistel lehekülgedel ära toodud asjaomaste ELi ühtlustamise õigusaktidega.

[Ελληνικά] Δήλωση πιστότητας ΕΕ

Κατασκευαστής: Ossila BV, Biopartner 3 building, Galileiweg 8, 2333 BD Leiden, NL.

Δηλώνουμε υπεύθυνα ότι ο αναφερόμενος εξοπλισμός συμμορφώνεται με τη σχετική νομοθεσία εναρμόνισης της ΕΕ που υπάρχει στις προηγούμενες σελίδες του παρόντος εγγράφου.

[Español] Declaración de conformidad UE

Fabricante: Ossila BV, Biopartner 3 building, Galileiweg 8, 2333 BD Leiden, NL.

Declaramos bajo nuestra única responsabilidad que el siguiente producto se ajusta a la pertinente legislación de armonización de la UE enumerada en las páginas anteriores de este documento.

[Français] Déclaration de conformité UE

Fabricant: Ossila BV, Biopartner 3 building, Galileiweg 8, 2333 BD Leiden, NL.

Déclarons sous notre seule responsabilité que le matériel mentionné est conforme à la législation en vigueur de l'UE présentée sur la/les page(s) précédente(s) de ce document.

[Hrvatski] E.U izjava o sukladnosti

Proizvođač: Ossila BV, Biopartner 3 building, Galileiweg 8, 2333 BD Leiden, NL.

Izjavljujemo na vlastitu odgovornost da je navedena oprema sukladna s mjerodavnim zakonodavstvom EU-a o usklađivanju koje je navedeno na prethodnoj(nim) stranici(ama) ovoga dokumenta.

[Italiano] Dichiarazione di conformità UE

Produttore: Ossila BV, Biopartner 3 building, Galileiweg 8, 2333 BD Leiden, NL.

Si dichiara sotto la propria personale responsabilità che l'apparecchiatura in elenco è conforme alla normativa di armonizzazione UE rilevante indicata nelle pagine precedenti del presente documento.

[Latviešu] ES atbils tības deklarācija

Ražotājs: Ossila BV, Biopartner 3 building, Galileiweg 8, 2333 BD Leiden, NL.

Ar pilnu atbildību paziņojam, ka uzskaitītais aprīkojums atbilst attiecīgajiem ES saskaņošanas tiesību aktiem, kas minēti iepriekšējās šī dokumenta lapās.

[Lietuvių k.] ES atitikties deklaracija

Gamintojas: Ossila BV, Biopartner 3 building, Galileiweg 8, 2333 BD Leiden, NL.

atsakingai pareiškia, kad išvardinta įranga atitinka aktualius ES harmonizavimo teisės aktus, nurodytus ankstesniuose šio dokumento

[Magyar] EU-s megfeleléségi nyilatkozat

Gyártó: Ossila BV, Biopartner 3 building, Galileiweg 8, 2333 BD Leiden, NL.
Kizárólagos felelősségünk mellett kijelentjük, hogy a felsorolt eszköz megfelel az ezen dokumentum előző oldalán/oldalain található EU-s összehangolt jogszabályok vonatkozó rendelkezéseinek.

[Nederlands] EU-Conformiteitsverklaring

Fabrikant: Ossila BV, Biopartner 3 building, Galileiweg 8, 2333 BD Leiden, NL.
Verklaart onder onze uitsluitende verantwoordelijkheid dat de vermelde apparatuur in overeenstemming is met de relevante harmonisatiewetgeving van de EU op de vorige pagina('s) van dit document.

[Norsk] EU-samsvarserklæring

Produsent: Ossila BV, Biopartner 3 building, Galileiweg 8, 2333 BD Leiden, NL.
Erklærer under vårt eneansvar at utstyret oppført er i overholdelse med relevant EU-harmoniseringslovverk som står på de(n) forrige siden(e) i dette dokumentet.

[Polski] Deklaracja zgodności Unii Europejskiej

Producent: Ossila BV, Biopartner 3 building, Galileiweg 8, 2333 BD Leiden, NL.
Oświadczamy na własną odpowiedzialność, że podane urządzenie jest zgodne ze stosownymi przepisami harmonizacyjnymi Unii Europejskiej, które przedstawiono na poprzednich stronach niniejszego dokumentu.

[Por tuguês] Declaração de Conformidade UE

Fabricante: Ossila BV, Biopartner 3 building, Galileiweg 8, 2333 BD Leiden, NL.
Declara sob sua exclusiva responsabilidade que o equipamento indicado está em conformidade com a legislação de harmonização relevante da UE mencionada na(s) página(s) anterior(es) deste documento.

[Română] Declarație de conformitate UE

Producător: Ossila BV, Biopartner 3 building, Galileiweg 8, 2333 BD Leiden, NL.
Declară pe proprie răspundere că echipamentul prezentat este în conformitate cu prevederile legislației UE de armonizare aplicabile prezentate la pagina/paginile anterioare a/ale acestui document.

[Slovensky] Vyhlásenie o zhode pre EÚ

Výrobca: Ossila BV, Biopartner 3 building, Galileiweg 8, 2333 BD Leiden, NL.
Na vlastnú zodpovednosť prehlasuje, že uvedené zariadenie je v súlade s príslušnými právnymi predpismi EÚ o harmonizácii uvedenými na predchádzajúcich stranách tohto dokumentu.

[Slovenščina] Izjava EU o skladnosti

Proizvajalec: Ossila BV, Biopartner 3 building, Galileiweg 8, 2333 BD Leiden, NL.
s polno odgovornostjo izjavlja, da je navedena oprema skladna z veljavno uskladitveno zakonodajo EU, navedeno na prejšnji strani/prejšnjih straneh tega dokumenta.

[Suomi] EU-vaatimusten mukaisuusvakuutus

Valmistaja: Ossila BV, Biopartner 3 building, Galileiweg 8, 2333 BD Leiden, NL.
Vakuutamme täten olevamme yksin vastuussa siitä, että tässä asiakirjassa luetellut laitteet ovat tämän asiakirjan sivuilla edellisillä sivuilla kuvattujen olennaisten yhdenmukaistamista koskevien EU-säädösten vaatimusten mukaisia.

[Svenska] EU-försäkran om överensstämmelse

Tillverkare: Ossila BV, Biopartner 3 building, Galileiweg 8, 2333 BD Leiden, NL.
Vi intygar härmed att den utrustning som förtecknas överensstämmer med relevanta förordningar gällande EU-harmonisering som finns på föregående sidor i detta dokument.

2. Safety

2.1 Use of Equipment

The Ossila Spectrophotometer is designed to be used as instructed. It is intended for use under the following conditions:



- Indoors in a laboratory environment (Pollution Degree 2).
- Altitudes up to 2000 m.
- Temperatures of 5°C to 40°C; maximum relative humidity of 80% up to 31°C.

The unit is supplied with a 24 VDC power adapter, in accordance with European Commission regulations and British Standards. Use of any other electrical power cables, adaptors, or transformers is not recommended.

2.2 Hazard Icons

The following symbols can be found at points throughout the rest of the manual. Note and read each warning before attempting any associated operations associated with it:

Table 2.1. Hazard warning labels used in this manual.

Symbol	Associated Hazard
	Electrical shock
	Optical radiation
	Ultraviolet radiation

2.3 Power Cord Safety



Emergency power disconnection options: use the power cord as a disconnecting method and remove from wall. To facilitate disconnect, make sure the power outlet for this cord is readily accessible to the operator.

2.4 Optical Hazards



The Ossila Spectrofluorometer emits intense optical radiation in the ultraviolet, visible, and infrared regions of the electromagnetic spectrum. The device has been assessed according to IEC 62471:2006 (Photobiological safety of lamps and lamp systems) and assigned to Risk Group 1.



2.5 Servicing

If servicing is required, please return the unit to Ossila Ltd. The warranty will be invalidated if:

- Modification or service has been carried out by anyone other than an Ossila engineer.
- The Unit has been subjected to chemical damage through improper use.
- The Unit has been operated outside the usage parameters stated in the user documentation associated with the Unit.
- The Unit has been rendered inoperable through accident, misuse, contamination, improper maintenance, modification, or other external causes.

2.6 Health and Safety – Servicing



Servicing should only be performed by an Ossila engineer. Any modification or alteration may damage the equipment, cause injury, or death. It will also void your equipment's warranty.

3. Requirements

Table 3.1 details the requirements for the Ossila Spectrophotometer, and the minimum computer specifications for the Spectrophotometry software.

Table 3.1. Ossila Spectrophotometer requirements.

Power	24 VDC
Operating Systems	Windows 11 (64-bit)
Processor	Dual Core 2 GHz
Memory	8 GB
Storage	270 MB
Monitor Resolution	1920 x 1080
Connectivity	USB-C 2.0

4. Unpacking

4.1 Packing List

The standard items included with the Ossila Spectrophotometer are:

- The Ossila Spectrophotometer.
- 24 VDC power adaptor.
- USB-C cable.
- USB memory stick loaded with software installer and user manual.



Figure 4.1. Ossila Spectrophotometer.

4.2 Damage Inspection

Examine the components for evidence of shipping damage. If damage has occurred, please contact Ossila directly for further action. The shipping packaging will come with a shock indicator to show if there has been any mishandling of the package during transportation.

5. Specifications

The Ossila Spectrophotometer specifications are shown in **Table 5.1**.

Table 5.1. Ossila Spectrophotometer specifications.

Spectral range (broadband)	380 – 1000 nm
Wavelength accuracy	<1 nm (in calibrated range)
Wavelength repeatability	<0.1 nm
Spectral resolution	Slit width dependant
Slit type	Manual – micrometer driven with 10 µm resolution
Slit size	50 µm – 6 mm (W) x 10 mm (H)
Maximum Sample size	75 (W) x 50 (H) x 5 (D) mm
Cuvette size	10 x 10 mm; maximum height 52 mm
Dimensions	280 (L) x 260 (W) x 100 (H) mm
Weight	2.7 kg

6. Installation

1. Connect the 24 VDC power adaptor to the power socket on the sample chamber.
2. Connect the sample chamber to your PC using a USB-C cable.
3. Set the power switches on the light source and sample chamber to the on position.

7. Spectrophotometer Parts



Figure 7.1. Ossila Spectrophotometer with parts labeled.

1	White light source
2	Input monochromator
3	Sample chamber
4	Absorption photodetector (silicon photomultiplier)

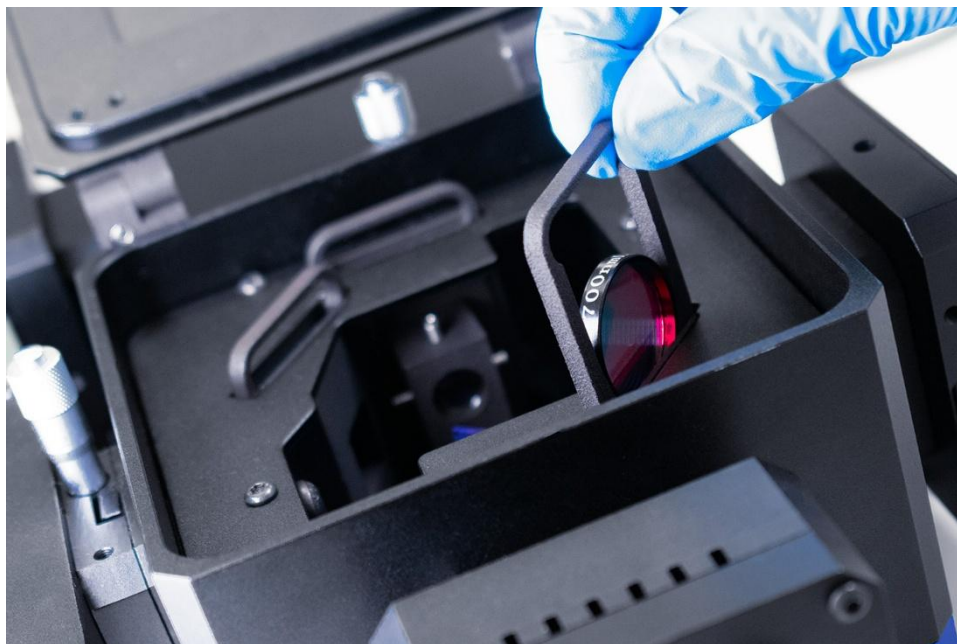

Figure 7.2. Placing a filter in a filter holder.

There are 2 filter holders in the in the sample chamber at the input and output. These take standard 25 mm diameter filters. To put a filter in or take a filter out of a holder, simply pull it up by the handle, place the filter in the recess, and push the handle back down.

8. Operation

The Ossila Spectrophotometer can be controlled either programmatically using serial commands, or through the Ossila Spectrophotometry software.

8.1 Command Library

When connected to a PC, the device will appear as a COM port, to which the serial commands can be sent. This section describes the command protocol and lists the available commands.

8.1.1 Command Format

Commands should be sent to the spectrophotometer in ASCII format, and responses from the spectrophotometer will also be in ASCII format.

All commands sent to the spectrophotometer have a start and end delimiter, `<` and `>` respectively. Only commands enclosed by these delimiters will be acknowledged by the device. If any invalid commands are sent between delimiters, the system will return `<Invalid Command>`.

Commands are either set commands with the format `<command value>` or query commands with the format `<command?>`.

Set commands take between 0 and 2 values and each `value` must be separated by a space. If a command is successfully implemented, it will be echoed back.

Query commands allow the user to find current system settings without modifying them. If a query command is successfully interpreted, the system will return `<command value>`.

Set commands that have a corresponding query command list both commands together. In these cases, the set command `value` and query command return `value` have the same format.

Values will be one of the following types depending on the command:

- `float` – Floating-point number
 - l. These can be sent in scientific notation (for example, `123e4` or `123E4`).
- `int` – Integer
 - l. If a floating-point number is sent instead, it will be rounded down to an integer.
- `bool` – Boolean (0 or 1)
 - l. Non-zero integers or floating-point numbers will be interpreted as 1.
- `str` – String
 - l. Only used as returns in some query commands.

8.1.2 Monochromator Commands

Monochromator commands and responses are prefixed with MC1. For a list of monochromator commands, see the [Ossila Monochromator user manual](#).

Command	Function
<MC1 command value>	Send a setting command to a monochromator.
<MC1 command?>	Send a query command to a monochromator.

8.1.3 Silicon Photomultiplier Commands

Silicon photomultiplier (SiPM) commands and responses are prefixed with PD1. For a list of silicon photomultiplier commands, see the [Ossila Silicon Photomultiplier user manual](#).

Command	Function
<PD1 command>	Send a read command to a SiPM.
<PD1 command value>	Send a setting command to a SiPM.
<PD1 command?>	Send a query command to a SiPM.

8.1.4 Setting Commands

Command	Values>Returns	Function
<LS1 X> <LS1?>	X - int - power of the light as a percentage	Sets the output power of the broadband white light source.

8.1.5 Query Commands

Command	Returns	Function
<device?>	<device str>	Returns the product code of the spectrophotometer.
<serial?>	<serial int>	Returns the serial number of the spectrophotometer.
<firmware?>	<firmware int.int.int>	Returns the firmware version of the spectrophotometer in the format major.minor.patch.

8.1.6 Example Python Code

```
# The PySerial Library is required to run this example
from serial import Serial

# Create a serial connection to the spectrophotometer
# A large timeout is used to allow for long SiPM read times at high precisions
with Serial('COM23', timeout=5, write_timeout=5) as SF:

    # Set the power level of the white light source to 20%
    SF.write('<LS1 20>'.encode())
    # The command will be echoed back if successful
    # The response will be in bytes, so it is decoded to a string for printing
    response = SF.readline().decode()
    # The response should be the same as the command sent
    print(f'Light source response: {response}')
    # Reading the response will also clear the read buffer for the next command

    # Set the output wavelength of the input monochromator to 600 nm
    SF.write('<MC1 600>'.encode())
    # As before, the command will be echoed back if successful and the read
    # buffer will be cleared for the next command
    _ = SF.readline()

    # Read the counts from the absorption photodetector
    SF.write('<PD1 read>'.encode())
    # The response includes new line characters, so these are stripped
    response = SF.readline().decode().strip()
    # The echoed command back and the start and end characters are also removed
    counts = response.strip('<>').split()[-1]
    print(f'Absorbance counts: {int(counts)}')
```

8.2 Spectrophotometry

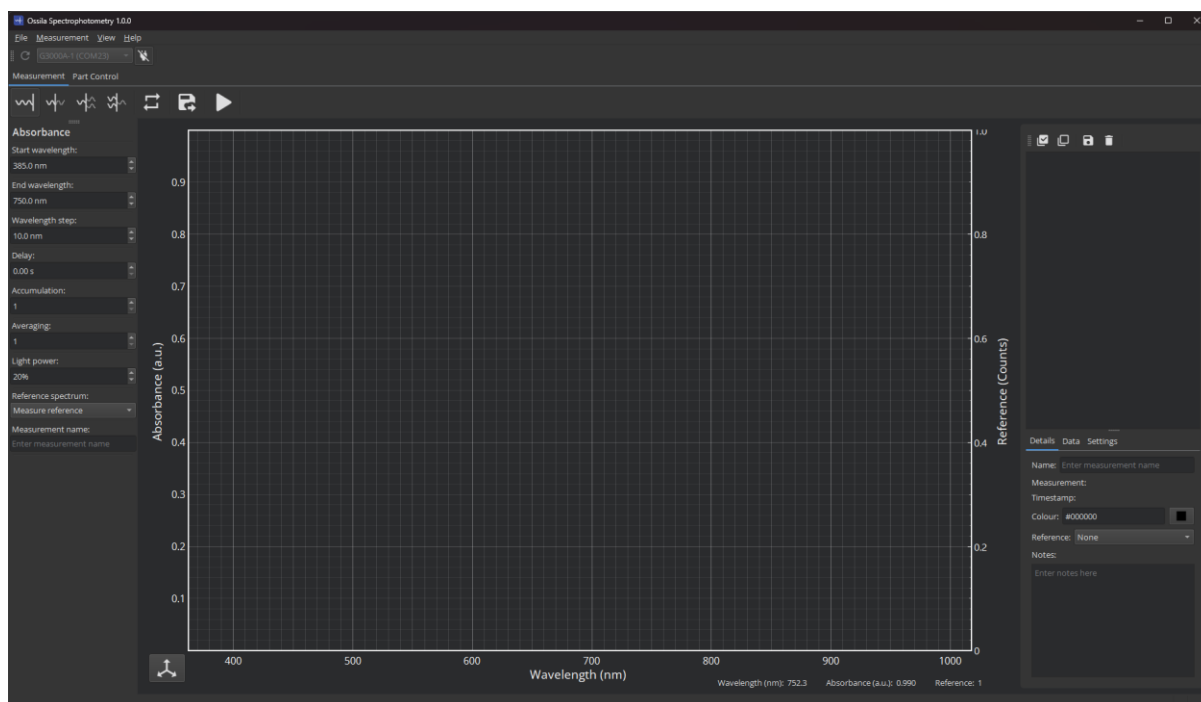

Figure 8.1. Ossila Spectrophotometry.

Ossila provides free software to allow for simple use of the Spectrophotometer. A Windows installer is provided on the USB drive supplied with the system and can be downloaded from our website at www.ossila.com/pages/software-drivers.

For details on how to use the software, see the [Ossila Spectrophotometry user manual](#).

9. Taking a Measurement

9.1 Absorbance/Transmission

1. Turn on the Spectrophotometer.
2. Remove any samples from the sample chamber.
3. Set the output power of the **white light source** and **UV light source** to 0%.
4. Read the **absorption photodetector** to get a background measurement.
5. Set the output power of the **white light source** to the desired level.
6. Sweep the **input monochromator** over the desired wavelength range, reading the **absorption photodetector** at each wavelength step to create a reference spectrum.
7. Place your sample in the sample chamber.
8. Sweep the **input monochromator** over the same wavelength range as used for the reference spectrum, reading the **absorption photodetector** at each wavelength step.
9. Subtract the background measurement from each reading of the reference and sample spectra.
10. Perform the appropriate calculations for absorbance or transmission using the reference and sample spectra.

The Spectrophotometry software automatically performs background readings and absorbance/transmission calculations when taking measurements.

9.2 Second Order Effects

As the spectrophotometer uses a grating monochromator to select wavelengths, second order effects occur and can impact your measurement. Second order effects occur where a monochromator's output wavelength is double the wavelength also produced by the light source. For example, if a monochromator can output at 400 nm and 800 nm, when the output is set to 800 nm, there will be second order effects from the 400 nm dispersed light. In these situations, both signals from the 800 nm first order light and the 400 nm second order light will be combined in the output. However, the second order 400 nm signal will be at a lower power than when the monochromator is selecting the 400 nm first order signal.

To avoid second order effects, you need to select a wavelength range that does not cover any wavelengths that are double any other wavelengths in the range. For example, to measure the absorbance between 380 nm and 1000 nm, you would need to do two measurements: the first between 380 nm and 750 nm and the second measurement between 750 nm and 1000 nm.

Additionally, if measurements do overlap into the second order, a filter should be used to prevent the second order light from illuminating the sample. In the previous example, a 750 nm long pass filter can be used to prevent second order signals.

10. Troubleshooting

Most of the issues that may arise will be detailed here. However, if you encounter any issues that are not detailed here, then contact us by email at info@ossila.com. We will respond as soon as possible.

Problem	Possible Cause	Action
No power/display	The power supply may not be connected properly.	Ensure the system is firmly plugged into the power supply, and that the plug is connected to both the adaptor and a working power socket.
	The power supply adaptor has a fault.	Contact Ossila for a replacement power supply adaptor.
Software does not start	The wrong version of Windows is installed on the computer.	Install the software on a computer with Windows 11.
	The software has not installed properly.	Try reinstalling the software.
Cannot connect to the system via USB	The USB cable may not be connected properly.	Ensure the USB cable is firmly plugged in at both ends.
	The USB cable may not be connected to a working USB port.	Try connecting the unit to a different USB port on the computer.
	The USB drivers may not be installed or may not have installed properly.	Try installing or reinstalling the USB drivers. If the drivers on the USB provided are not working, try following the Windows 7 installation instructions found in the Installation Guide.
	The USB cable is defective.	Try using a different USB-B cable, contact Ossila if necessary.
No signal from the photodetector	The light source is not switched on.	Turn the light source on.
	The slit is completely closed.	Increase the opening of the slit.

11. Related Products



Sapphire Substrates

Highly optically transparent substrates ideal for spectroscopic measurements.

Product codes: S2005



Optical Filters

Longpass and shortpass filters in a range of wavelengths.

Product code: G2103 / G2104 / G2105



Quartz Cuvettes

UV and IR Quartz Cuvettes for spectrophotometric setups to measure the optical properties of solvents and solutes.

Product codes: C2003 / C2004 / C2021



Substrate Cleaning Rack

Holds 20 substrates for a variety of processing techniques.

Product code: E101



USB Spectrometer

Fully programmable, compact UV-Vis-NIR optical spectrometer.

Product code: G2001A1 / G2001B2



USB LED Light Source Set

USB powered light sources in a range of wavelengths from UV to IR.

Product codes: G2011 / G2012